

Standard Handrail Stanchions

Manufactured to AS1657

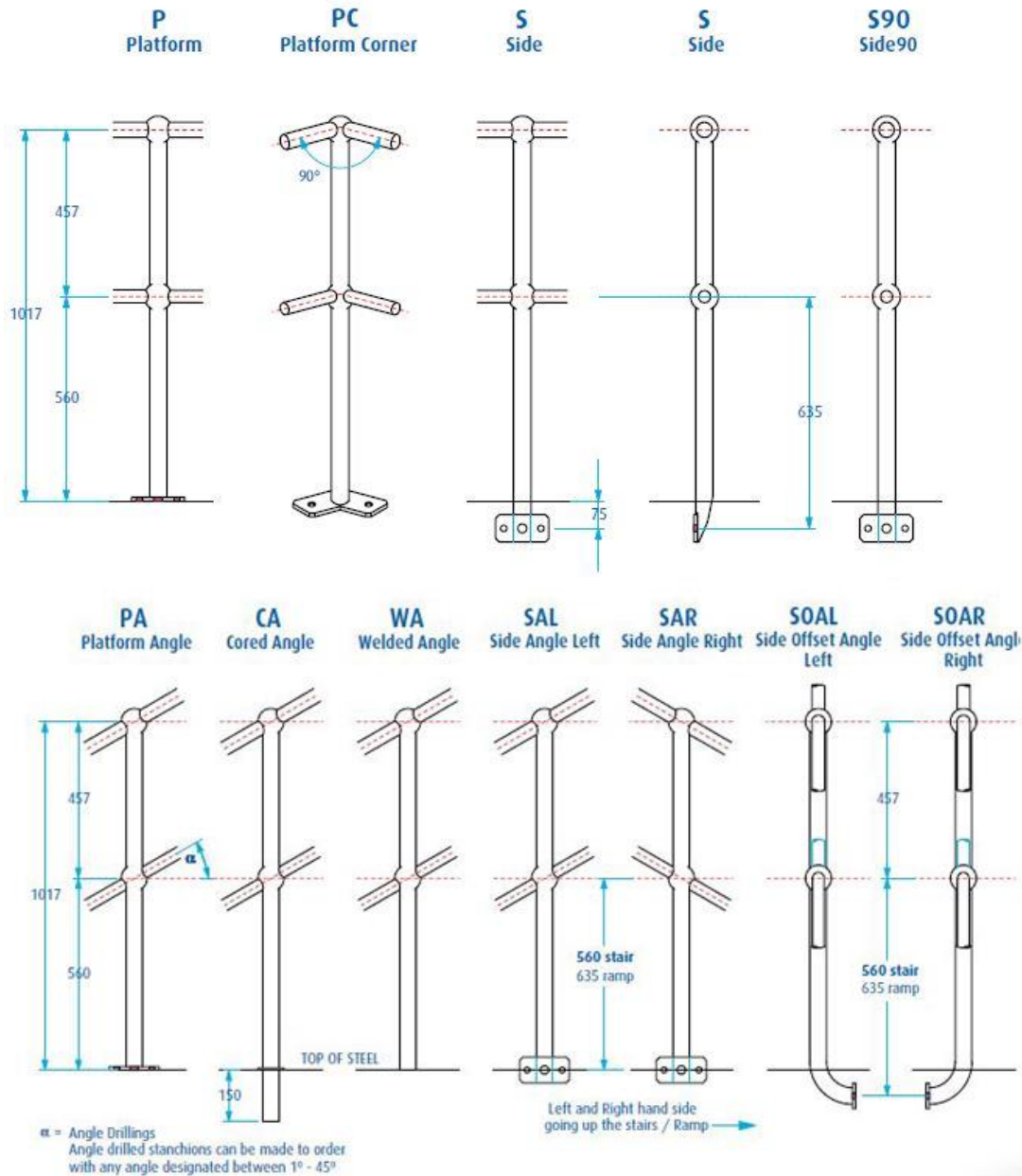

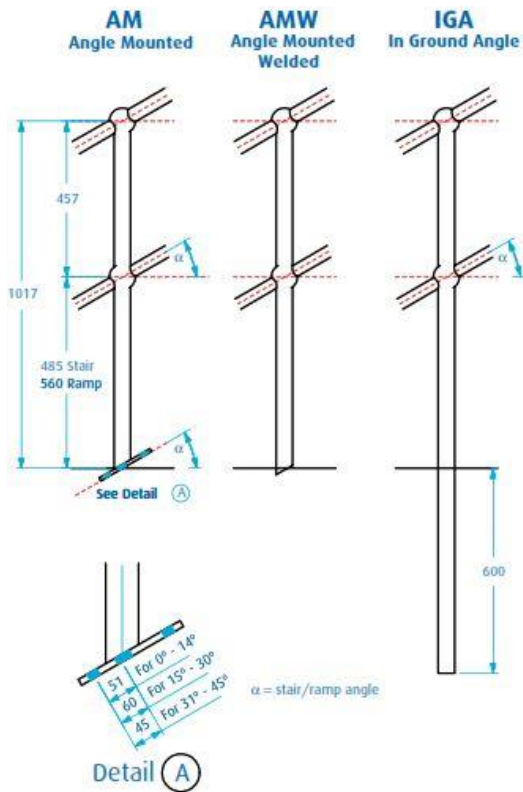
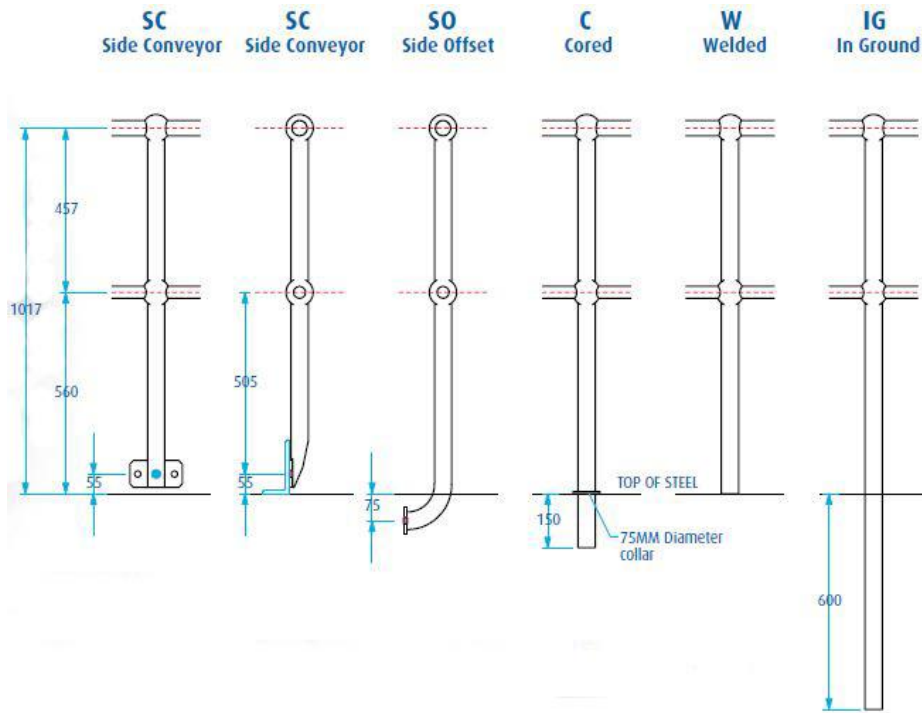

ALL STANCHIONS ALSO AVAILABLE DRILLED ONE SIDE ONLY (D.O.S.O.)

One Ball Stanchions

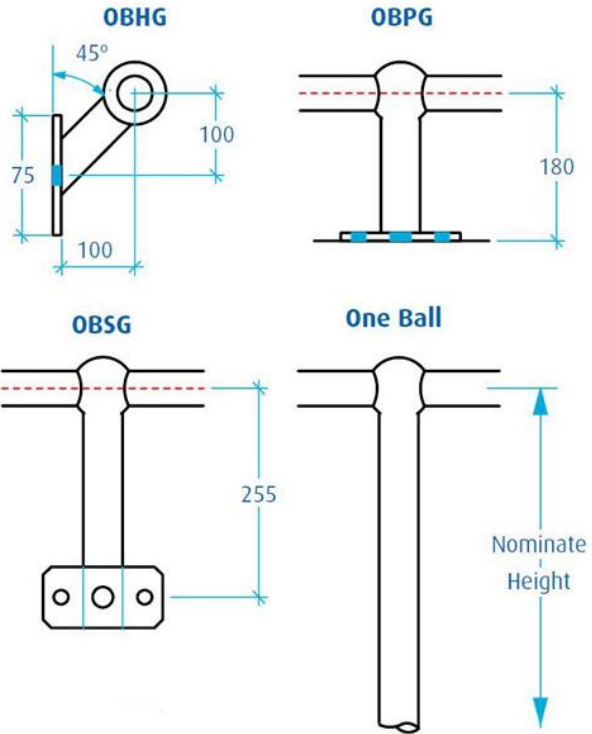

Side Offset Stanchions

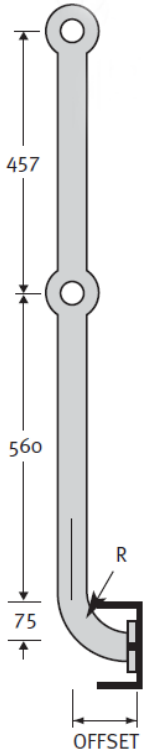

'SO' TYPE OFFSETS					
CHANNELS			UNIVERSAL BEAMS		
SIZE	STEEL OFFSET	ALUM. OFFSET	SECTION	STEEL OFFSET	ALUM. OFFSET
150 x 75	110	150	200UB	110	150
180 x 75	110	150	250UB	110	150
200 x 75	110	150	310UB	130	150
230 x 75	110	150	360UB	130	150
250 x 90	130	150	410UB	130	150
300 x 90	130	150	460UB	130	165
380 x 100	130	165	530UB	140	165

Horizontal Closure Bends

Standard Pipe

Steel Handrail: 32NB med / 32 SCH10

Steel Kneerail: 32NB med / 25 SCH10

Standard radius: 140mm centre line
Alum: 46 O.D. x 3.2mm

Available in other pipe sizes, talk to your sales consultant to discuss your requirements.

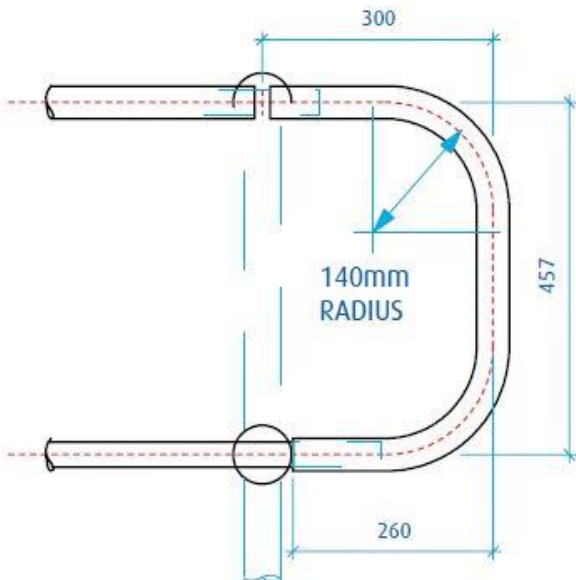

Angle Closure Bends

Standard Pipe

Steel Handrail: 32NB med / 32 SCH10

Steel Kneerail: 32NB med / 25 SCH10

Standard radius: 140mm centre line

Alum: 46 O.D. x 3.2mm

Available in other pipe sizes, talk to your sales consultant to discuss your project.

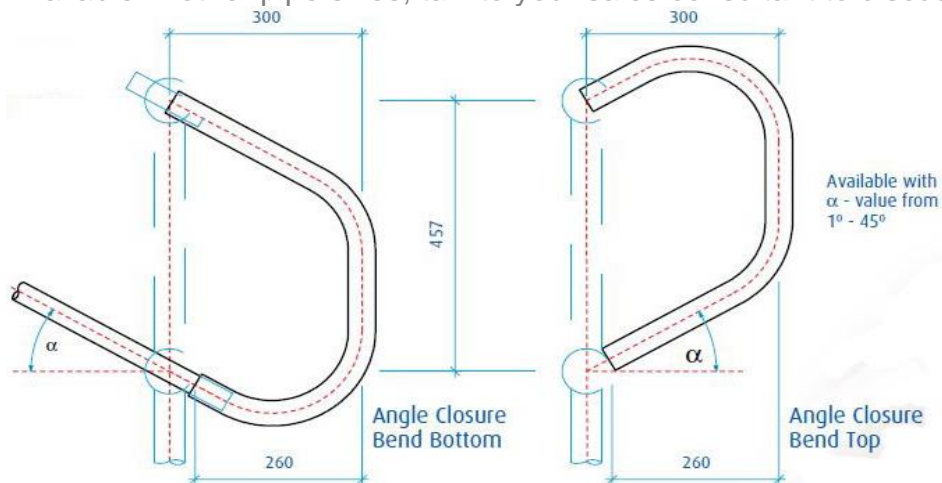

Rail Bends

Standard Pipe:	Handrail 32NB / 32 SCH10
	Kneerail 25NB / 25 SCH10
Angle α :	90° - 180°
Standard Radius:	140mm centre line
Alum:	46 O.D. x 3.5mm
Standard Leg:	300mm x 300mm
Non-Standard Leg:	L1 + L2 = < 6500
eg	L1 = 1000, L2 < 5500

Standard Pipe:	
	Handrail 32NB / 32 SCH10
	Kneerail 25NB / 25 SCH10
Angle α :	90° - 180°
Standard Radius:	140mm centre line
Alum:	46 O.D. x 3.5mm
Standard Leg:	300mm x 300mm
Non-Standard Leg:	L1 + L2 = < 6500
eg	L1 = 1000, L2 < 5500

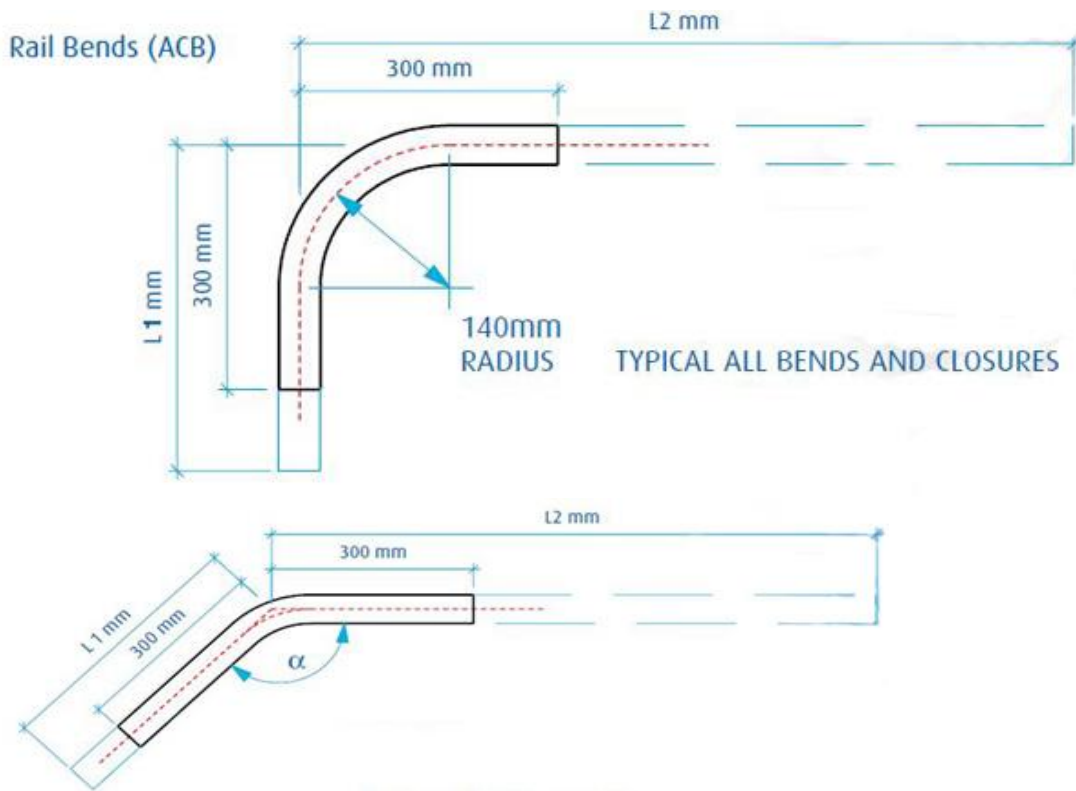

Slip Joints

Slip joints are used when joining the top or kneerail to another piece of pipe;

when an expansion joint is required
or when joining rails without using a butt weld

The slip joint can be fixed by welding, or by using pins.

Slip Joints	
Steel	Aluminium
SJ20G – suits 20NB rail	SJ40A – suits 40 OD rail
SJ25G – suits 25NB rail	SJ46A – suits 46 OD rail
SJ32G – suits 32NB rail	
SJ40G – suits 40NB rail	